

FIBER DISTRIBUTION BAYS (OSP - 15" DEEP - SEISMIC)

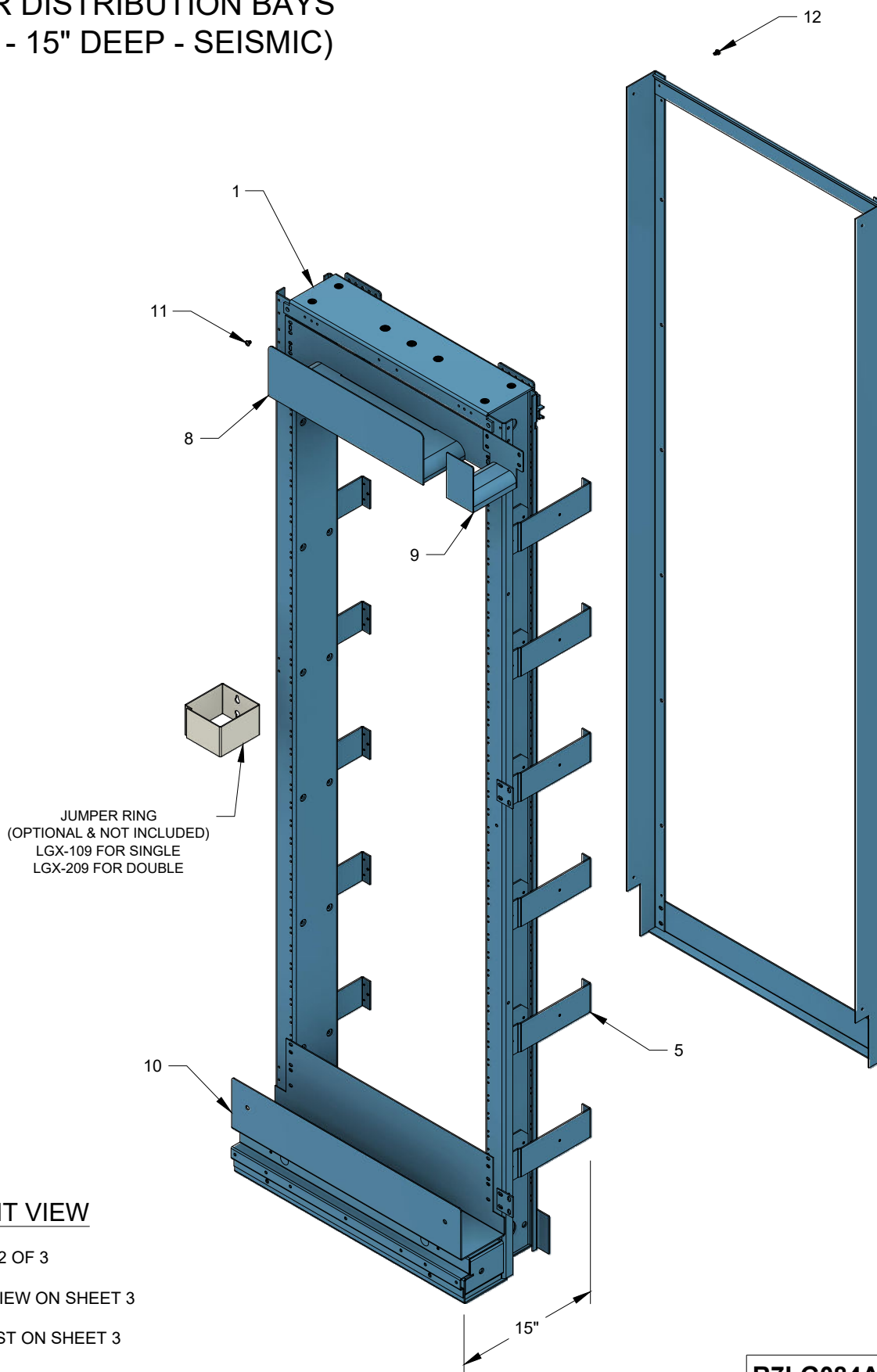

FRONT VIEW

SHEET 2 OF 3

REAR VIEW ON SHEET 3

ITEM LIST ON SHEET 3

R7LG084A15-3

(04/27/23)



Moreng Telecom Products
973-237-2001
www.morengtel.com

FIBER DISTRIBUTION BAYS (OSP - 12" & 15" DEEP - SEISMIC)

ITEM	DESCRIPTION	R7LG084A-3	R7LG084A15-3
1	NETWORK BAY KIT, SEE 5-24	1	1
2	LEFT UPRIGHT	1	1
3	RIGHT UPRIGHT	1	1
4	12" BRACKET	12	
5	15" BRACKET		12
6	TOP PLATE	1	1
7	BOTTOM PLATE	1	1
8	UPPER TROUGH	1	1
9	JUMP SUPPORT BRACKET	1	1
10	LOWER TROUGH	1	1
11	12-24 x 5/16" PHMS, ZC	68	68
12	12-24 x 3/8" PHMS, ZC	7	7

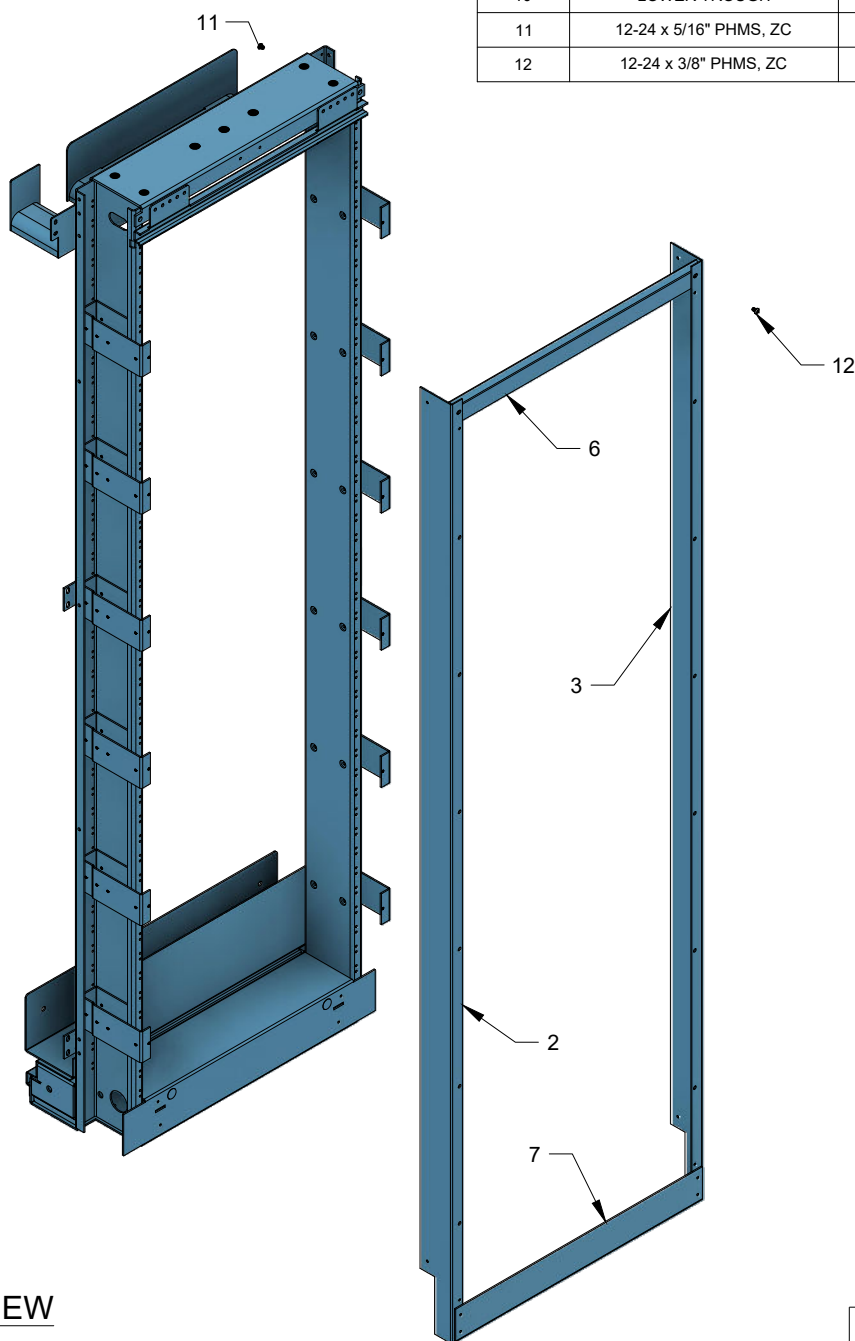

REAR VIEW

SHEET 3 OF 3

"D"	PART NUMBER
12	R7LG084A-3
15	R7LG084A15-3

(04/27/23)



Moreng Telecom Products
973-237-2001
www.morengtel.com